



ZAVOD ZA
GRADBENIŠTVO
SLOVENIJE

SLOVENIAN
NATIONAL BUILDING
AND CIVIL ENGINEERING
INSTITUTE



Member of
www.eota.eu

Dimičeva 12,
1000 Ljubljana, Slovenija

Tel.: +386 (0)1 280 44 72, +386 (0)1-280 45 37

Fax: +386 (0)1 280 44 84

e-mail: info.ta@zag.si

<http://www.zag.si>

European Technical Assessment

ETA-21/0597
of 01.08.2024

English version prepared by ZAG

General Part

**Technical Assessment Body issuing the
European Technical Assessment**

ZAG

Trade name of the construction product

TXH7

**Product family to which the construction
product belongs**

**33: Torque controlled expansion
anchor made of galvanised steel of
sizes M8, M10 and M12 for use in
non-cracked concrete**

Manufacturer

AS SYSTEM d.o.o.
Obrtniška ulica 14
3240 Šmarje pri Jelšah
Slovenia
www.as-system.si

Manufacturing plants

Plant 1 and 2

**This European Technical Assessment
contains**

10 pages including 3 annexes, which form
an integral part of the document

**This European Technical Assessment is
issued in according to Regulation (EU)
No 305/2011, on the basis of**

EAD 330232-01-0601,
edition December 2019

This version replaces

ETA-21/0597, issued on 21.10.2022

Translations of this European Technical Assessment in other languages shall fully correspond to the original issued document and should be identified as such.

Communication of this European Technical Assessment, including transmission by electronic means, shall be in full (excepted the confidential Annex(es) referred to above). However, partial reproduction may be made, with the written consent of the issuing Technical Assessment Body. Any partial reproduction has to be identified as such.

Specific Parts

1 Technical description of the product

The TXH7 in sizes M8, M10 and M12 is an anchor made of galvanised steel, which is placed into a drilled hole and anchored by torque-controlled expansion.

For the installed anchor see Annex A (1/3).

2 Specification of the intended use(s) in accordance with the applicable European Assessment Document (hereinafter EAD)

The performances given in Chapter 3 are only valid if the anchor is used in compliance with the specifications and conditions given in Annex B.

The provisions made in this European Technical Assessment are based on an assumed working life of the anchor of 50 years. The indications given on the working life cannot be interpreted as a guarantee given by the manufacturer, but are to be regarded only as a means for choosing the right products in relation to the expected economically reasonable working life of the works.

3 Performance of the product and references to the methods used for this assessment

3.1 Mechanical resistance and stability (BWR 1)

The basic work requirements for mechanical resistance and stability are listed in Annexes C (1/2) and C (2/2).

3.2 Safety in case of fire (BWR 2)

No performance determined.

3.3 General aspects relating to fitness for use

Durability and serviceability are only ensured if specifications of intended use according to Annex B are kept.

4 Assessment and verification of constancy of performance (hereinafter AVCP) system applied, with reference to its legal base

According to the decision 96/582/EC of the European Commission¹ the system of assessment and verification of constancy of performance (see Annex V to regulation (EU) No 305/2011) 1 apply.

5 Technical details necessary for the implementation of the AVCP system, as provided for on the applicable EAD

Technical details necessary for the implementation of the AVCP system are laid down in chapter 3 of EAD 330232-01-0601.

Issued in Ljubljana on 01.08.2024

Signed by:

Franc Capuder, M.Sc., Research Engineer

Head of Service of TAB

¹ Official Journal of the European Communities L 254 of 8.10.1996

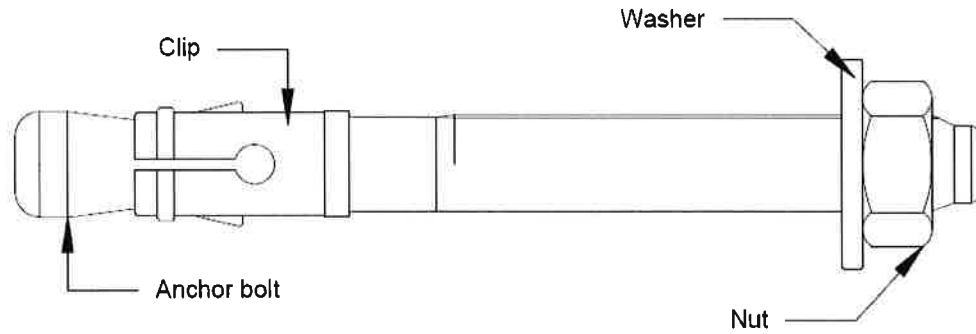

Marking on the sleeve: Product name: (TXH7)
 Diameter of an anchor: (e.g. M12)

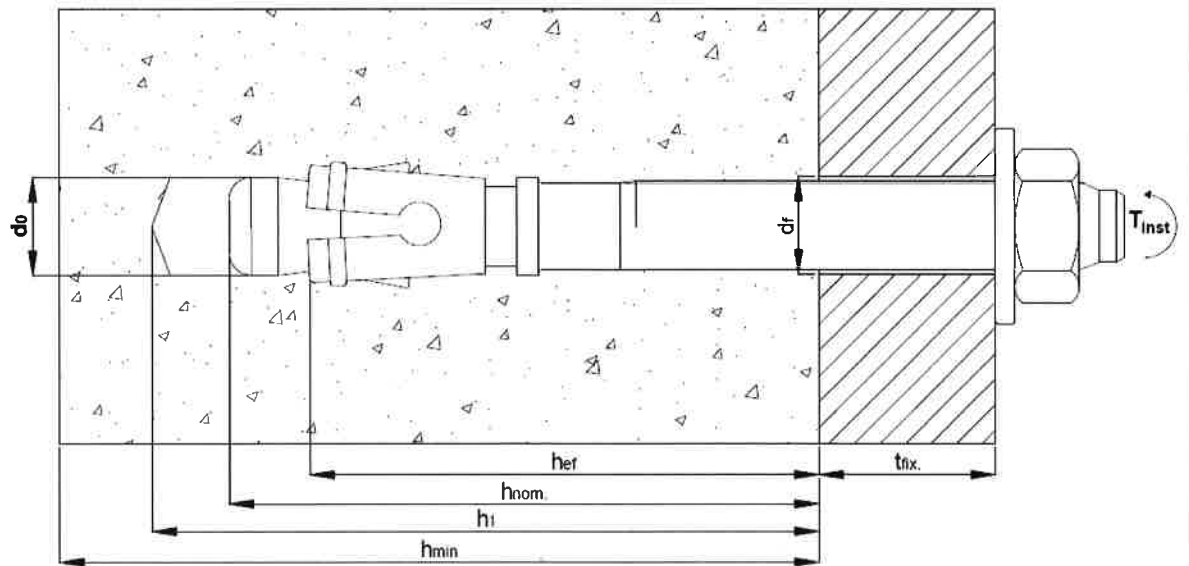

- h_{ef} effective anchorage depth
- h_{nom} anchor embedment depth
- h_0 depth of cylindrical drill hole at shoulder
- h_1 hole depth
- h thickness of concrete member
- d_0 drill hole diameter
- d anchor bolt/thread diameter
- t_{fix} thickness of the fixture

TXH7	Annex A (1/3)
Product description Product: Marking and installation condition	

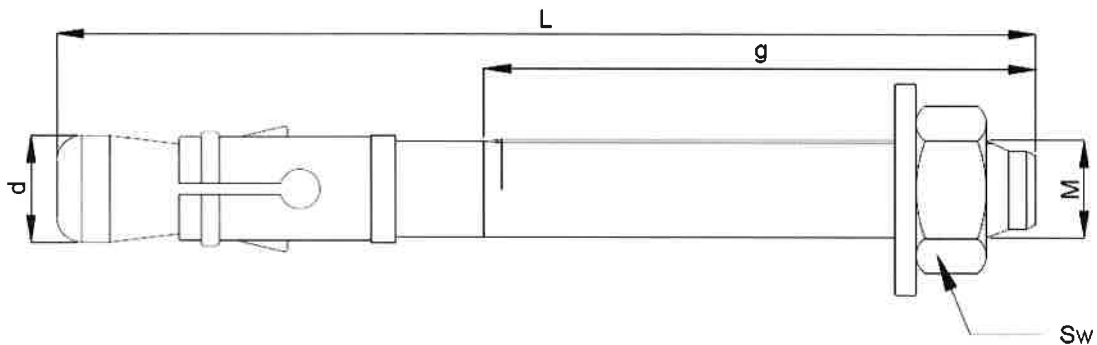

Table A1: Dimensions

		M8	M10	M12
Bolt	L_{min} [mm]	75	75	90
	L_{max} [mm]	150	150	150
	d [mm]	8	10	12
	g_{min} [mm]	40	35	45
	g_{max} [mm]	100	100	100
Hexagonal nut	S_w [mm]	13	17	19

TXH7	Annex A (2/3)
Product description Dimensions	

Table A2: Materials

Part	Component	Material	Coating
1	Anchor body (bolt)	Carbon steel	Galvanized, thickness of galvanization 5 µm
2	Expansion sleeve	Carbon steel in accordance with EN 10130 and EN 10131	Lamellar zinc of thickness 10 µm
3	Washer	Carbon steel in accordance with EN 7090 and DIN 125, DIN 9021 and DIN 440	Galvanized, thickness of galvanization 5 µm
4	Hexagonal nut	Carbon steel in accordance with EN 8673 and DIN 934	Galvanized, thickness of galvanization 5 µm

TXH7	Annex A (3/3)
Product description Materials	

Specifications of intended use

Anchorage subjected to:

- Static, quasi static load.

Base materials:

- Non-cracked concrete.
- Reinforced and unreinforced normal weight concrete of strength class C20/25 at minimum and C50/60 at maximum according to EN 206:2013+A2:2021.

Use conditions (Environmental conditions):

- The anchor may be used in concrete subject to dry internal conditions

Design:

- Anchorages are designed under the responsibility of an engineer experienced in anchorages and concrete work.
- Anchorages under static and quasi-static actions are designed in accordance with EN 1992-4:2018.
- Verifiable calculation notes and drawings are prepared taking into account of the load to be anchored. The position of the anchor is indicated on the design drawings (e.g. position of the anchor relative to reinforcement or to supports, etc.).

Installation:

- Anchor installation carried out by appropriately qualified personnel and under the supervision of the person responsible for technical matters on the site.
- Use of the anchor only as supplied by the manufacturer without exchanging the components of an anchor.
- Anchor installation in accordance with the manufacturer's specifications and drawings using the appropriate tools.
- Thickness of the fixture corresponding to the range of required thickness values for anchor size.
- Checks before placing the anchor to ensure that the strength class of the concrete in which the anchor is to be placed is in the range given and is not lower than that of the concrete to which the characteristic loads apply for.
- Check of concrete being well compacted, e.g. without significant voids.
- Cleaning of the hole of drilling dust.
- Anchor installation ensuring the specified embedment depth.
- Keeping of the edge distance and spacing to the specified values without minus tolerances.
- Positioning of the drill holes without damaging the reinforcement.
- In case of aborted hole: new drilling at a minimum distance away of twice the depth of the aborted hole or smaller distance if the aborted drill hole is filled with high strength mortar and if under shear or oblique tension load it is not to the anchor in the direction of load application.
- Application of the torque moment given in Annex B (2/2) using a calibrated torque wrench.

TXH7	Annex B (1/3)
Intended use Specifications	

Table B1: Installation data

			M8	M10	M12
Nominal diameter of drill bit	d_0	[mm]	8	10	12
Cutting diameter of drill bit	$d_{cut} \leq$	[mm]	8,45	10,45	12,50
Diameter of clearance hole in the fixture	d_f	[mm]	9	12	14
Depth of drill hole	$h_1 \geq$	[mm]	62	68	78
Effective anchorage depth	h_{ef}	[mm]	46	49	55
Embedment depth	h_{nom}	[mm]	55	61	72
Torque moment	T_{inst}	[mm]	15	45	65
Thickness of fixture-minimum	$t_{fix,min}$	[mm]	10	2	3
Thickness of fixture-maximum	$t_{fix,max}$	[mm]	85	77	63

Table B2: Minimum thickness, distances and spacing

			M8	M10	M12
Effective anchorage depth	h_{ef}	[mm]	46	49	55
Minimum thickness of the member	h_{min}	[mm]	100	100	120
Minimum spacing	s_{min}	[mm]	60	70	100
Minimum edge distance	c_{min}	[mm]	60	60	150

TXH7	Annex B (2/3)
Intended use Installation data	

	<p>Drill a hole with until prescribed depth (h_1).</p>
	<p>Clean hole with air pump.</p>
	<p>Set the anchor with hammer ensuring of minimum embedment depth (h_{nom}).</p>
	<p>Apply prescribed installation torque (T_{inst}).</p>
<p>TXH7</p>	
<p>Intended use Installation instructions</p>	<p>Annex B (3/3)</p>

Table C1: Characteristic values for tension loads in case of static and quasi-static loading for design method A acc. to EN 1992-4

Essential characteristics			Performance		
			M8	M10	M12
Steel failure					
Characteristic tension steel failure	$N_{Rk,s}$	[kN]	17,2	26,5	37,9
Partial safety factor	$\gamma_{Ms}^{1)}$	[-]	1,5		
Pull-through failure					
Characteristic resistance in non-cracked concrete C20/25	$N_{Rk,p}$	[kN]	8	10	14
Installation safety factor	γ_{inst}	[-]	1,0		
Increasing factor for $N_{Rk,p}$	ψ_C	C25/30	1,05	1,06	1,08
		C30/37	1,10	1,12	1,16
		C35/45	1,15	1,18	1,23
		C40/50	1,19	1,23	1,29
		C45/55	1,23	1,28	1,35
		C50/60	1,27	1,32	1,41
Concrete cone and splitting failure					
Effective anchorage depth	h_{ef}	[-]	46	49	55
Factor for non-cracked concrete	k_{ucr}	[-]	11,0		
Spacing	$s_{cr,N}$	[mm]	138	147	165
Edge distance	$c_{cr,N}$	[mm]	69	73,5	82,5
Spacing (splitting)	$s_{cr,sp}$	[mm]	230	250	290
Edge distance (splitting)	$c_{cr,sp}$	[mm]	115	125	145
Installation safety factor	$\gamma_{inst}^{1)}$	[-]	1,0		
Displacement under tension load					
Non-cracked concrete C20/25 – C50/60					
Service tension load	N	[kN]	3,8	4,8	6,7
Short term displacement	δ_{No}	[mm]	0,12	0,04	0,05
Long term displacement	$\delta_{N_{cr}}$	[mm]	0,12	0,12	0,12

¹⁾ In absence of other national regulations

TXH7

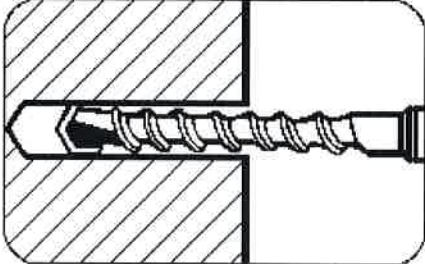
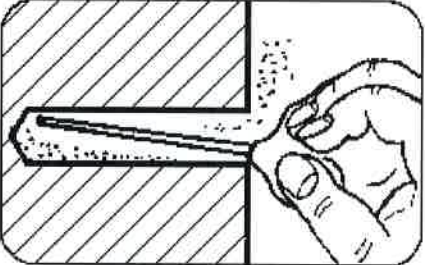
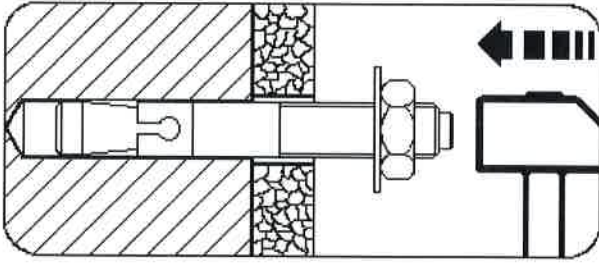
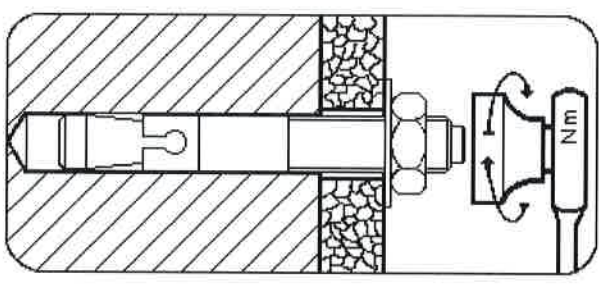
Design according to EN 1992-4

Characteristic resistance under tension load – BWR 1

Annex C (1/2)

Table C2: Characteristic values for Shear loads in case of static and quasi-static loading for design method A acc. to EN 1992-4

Essential characteristics			Performance		
			M8	M10	M12
Steel failure without lever arm					
Characteristic resistance	$V_{Rk,s}$	[kN]	8,5	13,8	24,0
Partial safety factor	γ_{Ms}	[Nm]	1,25	1,25	1,25
Factor for considering ductility	k_7	[-]		0,8	
Steel failure with lever arm					
Characteristic resistance	$M^0_{Rk,s}$	[Nm]	24,4	40,4	76,7
Partial safety factor	$\gamma_{Ms}^{1)}$	[mm]		1,25	
Concrete pryout failure					
k-factor	k_8	[-]		1,0	
Installation safety factor	γ_{inst}	[-]		1,0	
Concrete edge failure					
Effective length of anchor under shear load	l_{ef}	[mm]	46	49	55
Outside diameter of anchor	d_{nom}	[mm]	8	10	12
Installation safety factor	γ_{inst}	[-]		1,5	
Displacement under shear load					
Service shear load	V	[kN]	4,9	7,9	13,7
Short term displacement	δ_{v0}	[mm]	1,74	2,59	0,44
Long term displacement	$\delta_{v\infty}$	[mm]	2,61	3,88	0,66

¹⁾ In absence of other national regulations

TXH7	Annex C (2/2)
Design according to EN 1992-4 Characteristic resistance under shear load – BWR 1	